

## Falcon™ Standalone Unit

Designed to fit simply into your process to capture the value of spent precious metals



### About Falcon™

The beauty of the PhosponicsS Falcon™ is that it can be easily installed in processes to capture spent precious metals efficiently. This small unit allows you to evaluate PhosponicsS' smart silica technology swiftly and inexpensively. This safe, simple, low cost solution offers a flexible way to solve a complex problem and is available for purchase or rental.

### Benefits

- Maximise value by recovering precious metals in your waste stream
- Low cost technology assessment with both purchase and rental options available
- Obtain reliable, credible data at pilot scale whilst minimising risk
- Provides quality data quickly for rapid evaluation of the effectiveness of precious metal recovery
- Requires minimal manpower both at project and operator level



# PhosponicS

## Precious Metal Recovery Products

The Falcon™ is designed for use with PhosponicS' patented smart silica technology.

- Designed to recover only precious metals
- Stable in both aqueous and organic media
- Highly porous for optimised stream flow
- Larger surface area for higher loadings

### Technical Specifications

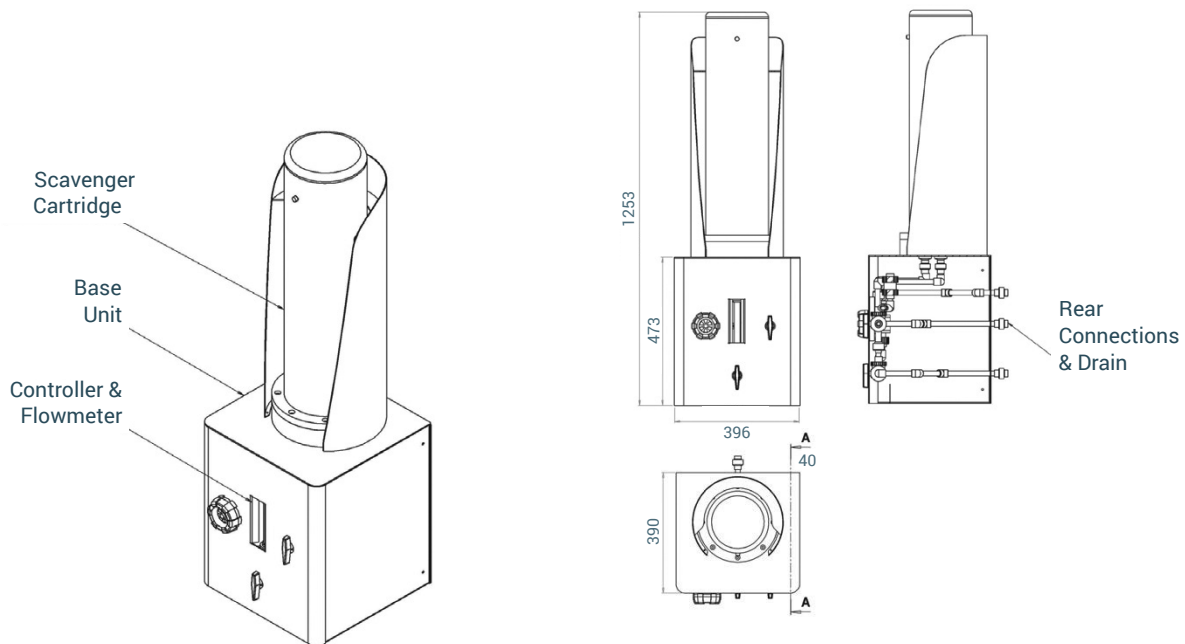

#### Falcon™

- 316 stainless steel base unit
- 20 L prepacked cartridges
- Weight 19.3 kg

#### Optional peristaltic pump

- Pump tube material: Marprene
- Flow range: 0 to 30 Lh<sup>-1</sup>
- Ingress protection: IP66
- Supply: 110 V or 240 V
- Control: Manual/remote/PROFIBUS

## Contact PhosponicS



**PhosponicS Limited**

7 The Quadrangle • Grove Business Park •  
Wantage • OX12 9FA • United Kingdom



+44 1635 953300



[www.phosponics.com](http://www.phosponics.com)



[sales@phosponics.com](mailto:sales@phosponics.com)

